



STEELWELD

ENVIRO PRODUCTS LTD

STEELWELD STROBE ECS 2000



The Steelweld Strobe ECS 2000 is a mobile eddy current separator using a powerful magnetic field to separate ferrous and non-ferrous metals such as aluminium and copper from a variety of materials. Incorporating the Master Magnets ECS200 ensures that optimal separation and a maximum yield is achieved. It can process high throughputs of various materials at maximum separation efficiency.

The Steelweld Strobe ECS 2000 comes with crawler tracks, an on-board diesel generator and hydraulic power pack allowing for easy site manoeuvrability and can be transported on a low loader trailer without permits. Its unique low feed height allows it to be directly fed from a trommel or conventional screener. With quick setup times and an easy to use push button control panel, this innovative design means high performance and low maintenance.

Features

- Horizontal vibratory feeder
- Low feed height
- Rare earth drum for ferrous metal separation
- 2000mm wide Master Magnets ECS for non-ferrous metal separation
- 3 integrated inclined discharge conveyors with hydraulic folding
- Powered by on board 65kW Generator or via mains electricity (customer supplied) via interlock switch
- Adjustable speed control on ECS rotor and ECS belt for optimal separation
- On board air compressor to allow cleaning of the machine
- On board working lights

Applications

- Municipal Solid Waste
- C&D Reclaim
- Incinerator Slag
- Biomass
- Shredded Wood
- Crushed Glass





STEELWELD

ENVIRO PRODUCTS

STEELWELD STROBE ECS 2000

Pan Feeder	2.46 long x 1.9 wide tray
Rare Earth Magnet	2090mm wide
Master Magnets ECS 200 Eddy Current	2000mm wide belt
Ferrous Metal Conveyor	800mm wide Chevron Belt
Non-Ferrous Metal Conveyor	800mm wide Chevron Belt
Non-Metallic Conveyor	1000mm wide Chevron Belt
Power	65kVA Onboard Diesel Generator
Transport Dimension	8.76m(l) x 3.35m(w) x 3.38m(h)
Weight	15800 kg

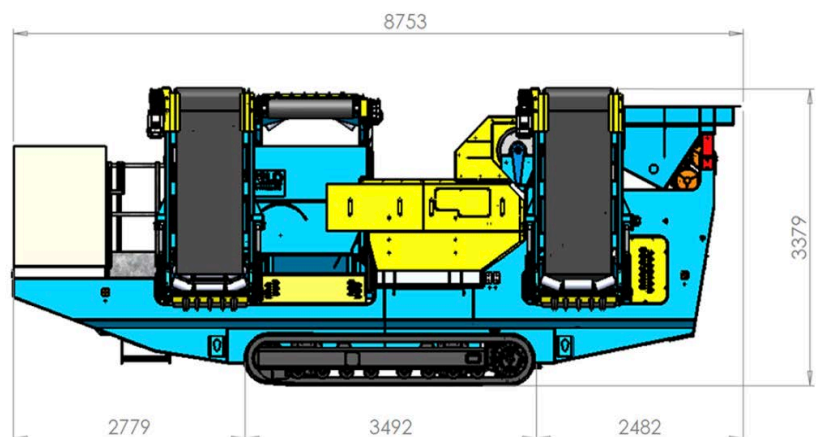

Dealer Information

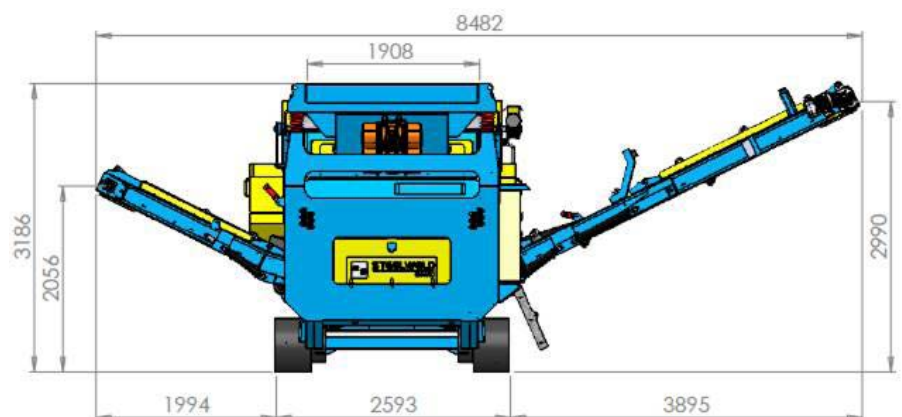
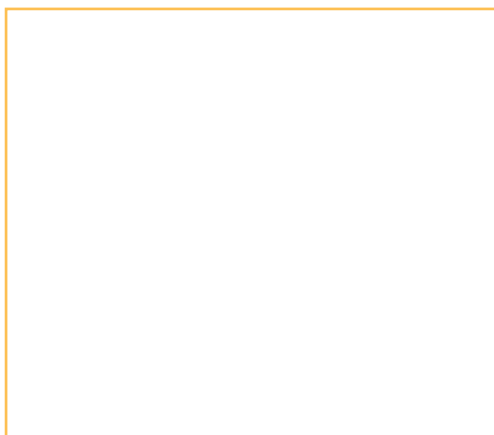

Steelweld Enviro Products Ltd
3 Ballyreagh Business Park
Sandholes Road
Cookstown BT80 9AR

T: 028 867 66495
F: 028 867 66496
E: sales@steelweld-enviro.com
www.steelweld-enviro.com