

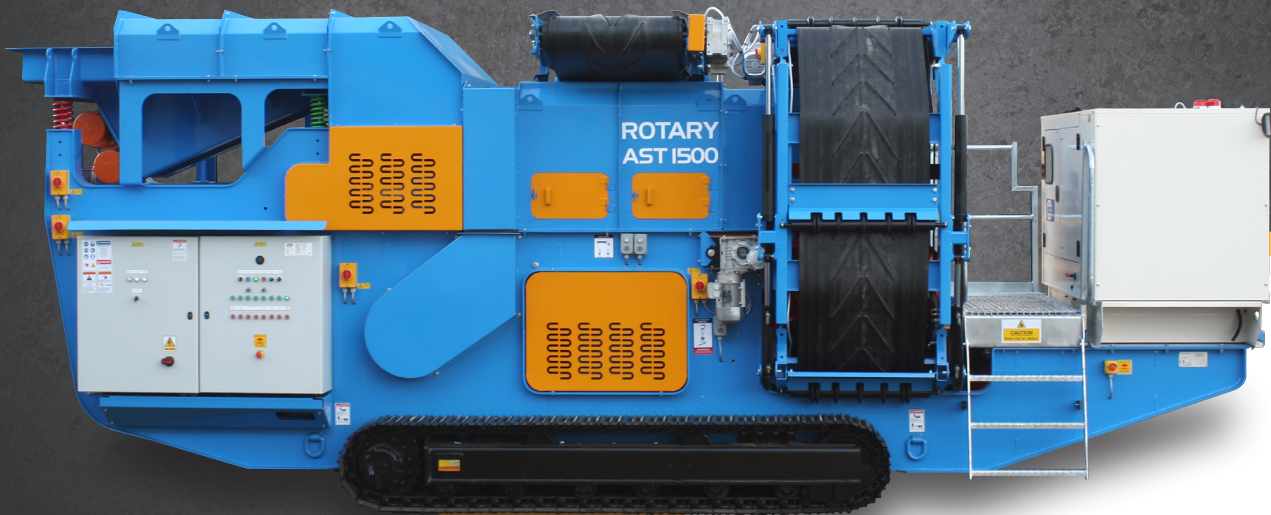

STEELWELD

ENVIRO PRODUCTS LTD

STEELWELD ROTARY AST 1500



The Steelweld Rotary AST 1500 is a tracked mobile air separator using powerful air fans to separate waste based on its density. The input material is separated into two fractions varying from light to heavy. Its unique low feed height allows it to be directly fed from a Trommel. It also has a fully adjustable feed belt, air system and air knife allowing for optimal separation control on a range of source materials.

Allowing ease of access to a variety of sites, The AST 1500 comes with crawler tracks, an on-board diesel generator and hydraulic power pack. The unit can be transported on a low loader trailer without permits. With quick set up times and an easy to use push button control panel, this innovative design means high performance and low maintenance.

Features

- Horizontal vibratory feeder
- Low feed height
- Fully adjustable 1500mm wide accelerator belt with speed control
- 5.5kW x 2 Blower fans with accurate air flow control
- Recirculating dust control system
- 2 integrated inclined discharge conveyors with hydraulic folding
- Removable dust covers over vibratory feeder and lights conveyor
- On board hydraulic power pack for crawler tracks control and hydraulic folding
- Powered by on board 65kW Generator or via mains electricity (customer supplied) via interlock switch
- On board air compressor to allow cleaning of the machine
- On board working lights

Applications

- C & D Reclaim
- Shredded Waste
- Compost
- Biomass
- Shredded Wood





STEELWELD

ENVIRO PRODUCTS LTD

STEELWELD ROTARY AST 1500

Pan Feeder	2.46 long x 1.4 wide tray
Accelerator Belt	1500mm wide plain speed adjustable
Lights Fraction Belt	800mm wide chevron
Heavies Fraction Belt	800mm wide chevron
Blower Fan	2x 5.5Kw (11Kw total) adjustable air control
Power	65Kva Perkins Diesel Generator
Transport Dimensions	8.2m(l) x 2.9m(w) x 3.2m(h)
Weight	12,000kg (estimate)

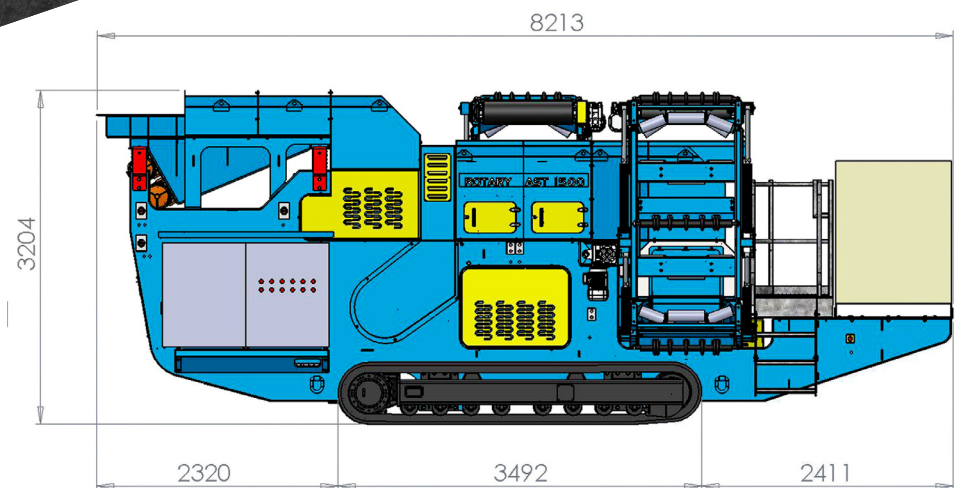

Dealer Information

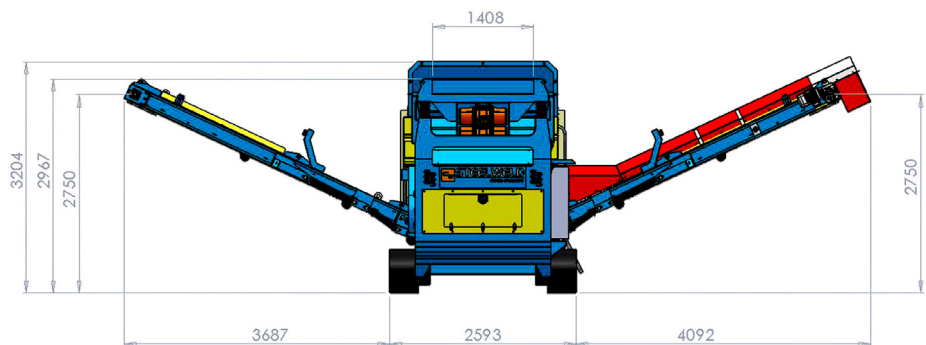

Steelweld Enviro Products Ltd
3 Ballyreagh Business Park
Sandholes Road
Cookstown BT80 9AR

T: 028 867 66495
F: 028 867 66496
E: sales@steelweld-enviro.com
www.steelweld-enviro.com